

Ion transit time effects in the plasma sheath

This article has been downloaded from IOPscience. Please scroll down to see the full text article.

1971 J. Phys. A: Gen. Phys. 4 934

(<http://iopscience.iop.org/0022-3689/4/6/021>)

View [the table of contents for this issue](#), or go to the [journal homepage](#) for more

Download details:

IP Address: 171.66.16.73

The article was downloaded on 02/06/2010 at 04:36

Please note that [terms and conditions apply](#).

Ion transit time effects in the plasma sheath

R. ROSA

Laboratório de Física e Engenharia Nucleares, Sacavém, Portugal

MS. received 11th January 1971, in revised form 25th May 1971

Abstract. The equation of motion of the ions in an ion-rich plasma sheath as well as the appropriate initial conditions that hold for all frequencies well below the electron plasma frequency are obtained. The problem of ion motion in the case when a small amplitude rf voltage is applied to the sheath is solved. One thus obtains the sheath admittance as a function of the plasma parameters, the applied dc voltage and frequency. One reaches the conclusion that, besides the electron contribution, there also exists an ion contribution to the sheath conductance and that the sheath susceptance, although dominated by a capacitive term, cannot be wholly ascribed to this one alone. Simple equivalent circuits are proposed to represent the plasma sheath in the low and in the high frequency limits. The sheath admittance was computed over the frequency range in which the ion transit time effects are relevant. Finally, the advantage in employing the rf probe technique near the ion plasma frequency is pointed out.

1. Introduction

The object of this paper is the study of the influence of the ion transit time on the rf admittance of the plasma sheath.

In the past, rf probe techniques have occasionally been employed for plasma diagnostics. These techniques have certain advantages over the more conventional dc probing methods but a number of technical difficulties, as well as theoretical questions, remain on the way to the full implementation of the rf methods (Oliver *et al.* 1970).

It has been predicted and demonstrated that the sheath presents parallel conductive and capacitive components to an applied rf voltage (see Montgomery and Holmes 1963, Butler and Kino 1963, Crawford and Grard 1966).

At frequencies below the ion plasma frequency the ion current across the sheath is at all times in equilibrium with the applied voltage and is often assumed to obey Child's law for a space charge limited flow. For frequencies above the ion plasma frequency, but still below the electron plasma frequency, the ion density profile remains frozen and only the electrons react to the rf field. In the light of these models, theoretical considerations predict a sheath capacitance which is somewhat smaller at higher frequencies than at lower frequencies. The sheath conductance is commonly supposed to be wholly associated with the electron flow and to be independent of the applied frequency provided this is well below the electron plasma frequency.

Sheath properties are dominated by transit time effects at and near the two plasma frequencies. The rf sheath behaviour near the electron plasma frequency, when electron inertia produces resonance effects, is already well understood (Buckley 1966, 1967 and Montgomery and Holmes 1963). The rf sheath behaviour near the ion plasma frequency, on the other hand, has received little attention so far. Some authors have observed an ion resonance effect which, it is hoped, may become useful in plasma diagnostics (Toepfer 1967). The theory of this effect, however, is not yet completed; difficulty arises from this being a nonlinear phenomenon (Virmont 1969). In this

paper we offer the exact solution for the small signal admittance of an ion-rich plasma sheath for all frequencies well below the electron plasma frequency.

It is our belief that rf probe data obtained near the ion plasma frequency can be of practical interest in plasma diagnostics. In fact, the conductance and susceptance components of the sheath admittance are of comparable magnitudes in this frequency range so that this range appears suitable for the simultaneous measurement of the two admittance components. In such circumstances both the plasma density and the electron temperature may be obtained in one single measurement from the phase and amplitude of the sheath admittance.

2. Theory

2.1. *The sheath model*

In order to study the ion transit time effects in the plasma sheath we shall take a simplified model of the sheath. It will be assumed, in particular, that the electron density drops to negligibly small values within the sheath. This situation is actually approached when either the wall is biased increasingly negative or at floating potential if the ion mass is increasingly large. The electron density will then drop immediately after crossing the plasma edge and into the sheath while the ion motion follows closely a simple space charge limited flow. It is well known that the ion stream past the plasma edge must exceed the Bohm speed c as a result of being accelerated in the small field of the transition region. For a zero-temperature flow the Bohm speed simply reads $c = (kT_e/m_i)^{1/2}$ where T_e is the electron temperature and m_i is the ion mass (Bohm 1949). The electric field at the plasma edge is very small, compared with the field inside the sheath, provided the plasma dimensions are much larger than the sheath thickness. It becomes negligibly small when, once again, the wall is biased increasingly negative or at floating potential if the ion mass is increasingly large.

In the actual conditions of an electric discharge the boundary between plasma and sheath is ill defined. However, in the limit when the ratio of the Debye length to the discharge dimension vanishes the transition from the plasma region to the sheath region becomes abrupt. The plasma boundary can then be clearly identified as the Tonks–Langmuir boundary (Self 1963, 1965).

In actual conditions, too, the ion flow shows a certain energy distribution that is associated with the particular generation mechanism and discharge geometry (Self 1965). Accordingly, the ion motion across the sheath cannot in general be wholly described in terms of a one-particle model as in the case of a zero-temperature flow. Moreover, the average ion velocity at the Tonks–Langmuir boundary is in general somewhat greater than the lower limit given by the Bohm criterion for sheath formation.

We shall assume, throughout the present paper, a one dimensional (plane) sheath, a Maxwellian electron gas, a cold beam of singly charged ions entering the sheath at the Bohm speed c and a collisionless regime.

For the study of the ion transit time effects in the sheath it is necessary to solve the equation of motion of the ions in the presence of a perturbation.

Take as coordinate system an x axis normal to the plane of the sheath, directed from the plasma to the wall, and place its origin at a very short distance d_x from the equilibrium position of the plasma edge, just inside the sheath (see figure 1). The plasma edge will move when a perturbation is imposed. However, we shall restrict ourselves to a very small perturbation, so small that the plasma edge will always stay within a distance d_x from its equilibrium position.

For each quantity q of equilibrium value q_0 take perturbations of the form $q_1 \exp i\omega t$. The angular frequency ω is always real but q_1 will in general be a complex number. We limit ourselves to perturbations of vanishingly small amplitude so that

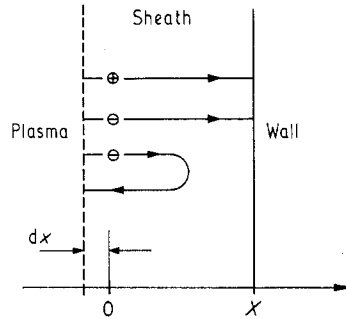

Figure 1. The plasma and an ion-rich sheath next to a negatively charged wall.

our equations can be linearized throughout. The distance dx from the coordinate origin to the equilibrium position of the plasma edge is supposed to approach zero together with the perturbation amplitude.

2.2. The equation of motion

Ions entering the sheath move under the field produced by the charges on the wall and by the charges in the space. The influence of the space charge is governed by Poisson's equation

$$\frac{\partial E}{\partial x} = \frac{en_1}{\epsilon_0} \quad (1)$$

where e denotes the elementary electric charge ($e > 0$) and n_1 the ion number density. The total current density, convection plus displacement, is

$$J = j_i - j_e + \epsilon_0 \frac{\partial E}{\partial t} \quad (2)$$

where j_i and j_e are the ion and electron contributions to the convection current ($j_e > 0$). It is well known that total current is everywhere continuous though it exists in different forms in different regions. One accordingly has

$$\frac{\partial J}{\partial x} = 0. \quad (3)$$

Elementary considerations show the electron transit time in the sheath to be of the order of one period of the electron plasma oscillation so that, in order to neglect electron inertia, we shall restrict ourselves to frequencies well below the electron plasma frequency. This being the case, the electron current through the sheath is at every moment in equilibrium with the instantaneous field and must therefore satisfy a continuity equation of the form

$$\frac{\partial j_e}{\partial x} = 0. \quad (4)$$

Consider an observer moving with the ion beam. He would see a changing field given by the total derivative in the Eulerian variables (x, t)

$$\frac{dE(x, t)}{dt} = \frac{\partial E}{\partial t} + v_i \frac{\partial E}{\partial x}$$

v_i being the ion speed. From this and equations (1) and (2) it follows that

$$\frac{dE(x, t)}{dt} = \frac{1}{\epsilon_0} (J + j_e).$$

Changing from Eulerian variables (x, t) to Lagrangian variables (t, t_0) , where t_0 is the time at which the ion beam crosses the surface $x = 0$, one can replace the foregoing equation by

$$\frac{\partial E(t, t_0)}{\partial t} = \frac{1}{\epsilon_0} (J + j_e).$$

Now, the equation of motion for the ion beam reads, in Lagrangian variables

$$m_i \frac{\partial^2 x(t, t_0)}{\partial t^2} = eE(t, t_0)$$

m_i being the ion mass. Taking its derivative and replacing the field for the current one arrives at

$$\frac{\partial^3 x(t, t_0)}{\partial t^3} = \frac{e}{\epsilon_0 m_i} (J + j_e). \tag{5}$$

The right hand side of this equation is a function of t alone because J and j_e , being independent of x (equations (3) and (4)), are also independent of t_0 . This equation is readily integrated along the path of the ion beam, for any initial time t_0 , leading to the complete description of the ion motion in the sheath. Not surprisingly equation (5) is, apart from the electron current term, identical to 'Llewellyn's equation' that is often used in connection with the kinetic description of diode regions (Llewellyn 1941).

2.3. *The initial conditions*

When crossing the plane $x = 0$ at time $t = t_0$ the ion beam has a certain initial speed $v_i(t_0)$ and acceleration $a_i(t_0)$.

It should be noticed that the rf field does not penetrate the plasma region provided the frequency is well below the electron plasma frequency (Montgomery and Holmes 1963). The initial velocity perturbation is therefore entirely due to the acceleration by the field in the thin layer between the plasma edge and the plane $x = 0$. Taking $\partial E/\partial x = en_i/\epsilon_0$ and $dv_i = eE dt/m_i$ one can estimate $dv_i/c < \Pi_1^2 dx^2/c^2$, where $\Pi_1 = (e^2 n_i/\epsilon_0 m_i)^{1/2}$ is the ion plasma frequency at the plasma edge. We see that dv_i is of the second order in dx . Hence it follows that the equilibrium value and the first order perturbation of the initial velocity are, in the limit when $dx \rightarrow 0$

$$v_{i0} = c \qquad v_{i1} = 0 \qquad (t = t_0). \tag{6}$$

With regard to the initial ion current density one can see, invoking the ion continuity equation $\partial n_i / \partial t + \partial(n_i v_i) / \partial x = 0$ and following an argument similar to the previous one, that one has

$$j_{i0} = en_i c \quad j_{i1} = 0 \quad (t = t_0) \quad (7)$$

where n_i refers to the plasma edge.

Consider next the equation for total current density (equation (2)) at the plane $x = 0$. To first order and in view of equation (7) it simply reads $J_1 = -j_{e1} + \epsilon_0 \partial E_1 / \partial t$. If one introduces the ion acceleration $a_i = eE/m_i$ and takes the limit $dx \rightarrow 0$ one arrives at

$$a_{i0} = 0$$

$$a_{i1} = -\frac{ie}{\epsilon_0 m_i \omega} (J_1 + j_{e1}) \quad (t = t_0). \quad (8)$$

Equations (6) and (8) are the appropriate initial conditions for the ions crossing the plane $x = 0$ at an initial time $t = t_0$.

2.4. The electron current

Consider the electron current in a little more detail now. Let V denote the potential drop across the sheath and define $\eta \equiv eV/kT_e$ ($V, \eta > 0$). The electron gas being maxwellian and the electron inertia being negligible, the instantaneous current to the wall is

$$j_e = en_e \left(\frac{kT_e}{2\pi m_e} \right)^{1/2} \exp(-\eta)$$

where n_e is the electron density at the plasma edge, T_e the temperature of the electron gas and m_e the electron mass.

In equilibrium, equating the electron and ion currents and imposing charge neutrality at the plasma edge ($n_e = n_i$) one obtains the floating potential

$$\eta_0^* = \frac{1}{2} \ln \left(\frac{m_i}{2\pi m_e} \right). \quad (9)$$

For very small perturbations of the applied voltage, everything else being constant, one has $j_{e1} = -j_{e0} \eta_1$. It can easily be verified that this electron current perturbation can be written in the form

$$j_{e1} = -\frac{\epsilon_0}{c} \Pi_1^2 \exp(\eta_0^* - \eta_0) V_1 \quad (10)$$

that will be of use further on.

2.5. The sheath structure

The integration of the equation of motion (5) subjected to the appropriate initial conditions (6) and (8) is straightforward and can be found elsewhere. See, for instance, the work of Birdsall and Bridges (1966) where the integration of 'Llewellyn's equation' is dealt with in detail. One eventually arrives at the solution of the ion motion $x = x(t, t_0)$. It is now convenient to define the sheath thickness X and the ion transit time across the sheath τ_i , these two quantities obviously satisfying the condition $X(t) = x(t, t - \tau_i)$. For the case of the steady state sheath one obtains

$$X_0 = \left(1 + \frac{\lambda^2}{6} \right) c \tau_{i0} \quad (11)$$

where $\lambda \equiv \Pi_1 \tau_{i0}$. Once the ion motion is fully known one can next obtain the potential drop across the sheath

$$V(t) = \frac{m_1}{e} \int_t^{t-\tau_1} \frac{\partial^2 x}{\partial t^2} \frac{\partial x}{\partial t_0} dt_0.$$

At equilibrium, this simply reads

$$\eta_0 = \left(1 + \frac{\lambda^2}{4}\right) \frac{\lambda^2}{2}. \tag{12}$$

Equations (11) and (12) give a full description of the steady state sheath structure. On the basis of these equations one finds that when $\eta_0 \gg 1$ the voltage against current characteristic approaches Child's law. It can also be verified that the mean electric field in the sheath increases with the applied voltage in spite of the growing sheath thickness. Thus it becomes clear that the condition $\eta_0 \gg 1$ should be satisfied in order to justify two of the hypotheses upon which the present sheath model is based, namely, negligible electron density in the sheath and negligible electric field at the plasma edge.

2.6. *The sheath admittance*

It is now convenient to define the dimensionless parameter $\theta \equiv \tau_{i0} \omega$ that is known as the transit angle of the ions in the sheath.

The potential drop across the sheath is, to first order

$$V_1 = - \frac{c}{\epsilon_0 \omega^2} \Psi(\lambda, \theta) (J_1 + j_{e1}).$$

$$\Psi(\lambda, \theta) \equiv i\theta + \frac{\lambda^2}{\theta^2} \left(\frac{i\theta^3}{6} + i\theta \{ \exp(-i\theta) + 1 \} + 2 \{ \exp(-i\theta) - 1 \} \right). \tag{13}$$

Introducing the (small amplitude) sheath admittance (per unit area) $Y \equiv J_1/V_1$ and replacing the electron current with the help of equation (10) one finally arrives at

$$\frac{Y}{(\epsilon_0 \Pi_1^2 / c)} = \exp(\eta_0^* - \eta_0) - \frac{\theta^2}{\lambda^2} \Psi^{-1}(\lambda, \theta). \tag{14}$$

This is the formula for the sheath admittance which we wanted to obtain. The first term of Y is frequency independent and stands for the sheath conductance associated with the inertia-free electron flow G_e . The second term of Y is a complex quantity. Its imaginary part represents the sheath susceptance B and its real part the ion contribution to the sheath conductance G_1 . Of course, $Y = G_e + G_1 + iB$, where

$$G_e = \left(\frac{\epsilon_0 \Pi_1^2}{c} \right) \exp(\eta_0^* - \eta_0)$$

$$G_1 = - \left(\frac{\epsilon_0 \Pi_1^2}{c} \right) \left(\frac{\theta}{\lambda} \right)^2 \operatorname{Re} \Psi^{-1}(\lambda, \theta)$$

$$B = - \left(\frac{\epsilon_0 \Pi_1^2}{c} \right) \left(\frac{\theta}{\lambda} \right)^2 \operatorname{Im} \Psi^{-1}(\lambda, \theta). \tag{15}$$

G_e is determined by the applied dc voltage alone and is made increasingly small when biasing the probe increasingly negative. Both B and G_i depend on the applied frequency too. B can be interpreted, to a good approximation, as being capacitive. G_i is rather more complicated, however, in that it cannot be easily interpreted in terms of an equivalent circuit.

3. Results and discussion

3.1. The sheath equivalent circuit

It is our purpose now to seek an equivalent electrical circuit to represent the sheath rf behaviour.

To start with, it is obvious from equation (14) that the sheath is a parallel association of two components the first of which is the conductance term due to the electron flow, $G_e = 1/R_e$. With regard to the second component in this parallel association it is convenient to begin with a few general remarks concerning equivalent circuits.

Given a physical system there may exist an admittance or an impedance function of the form $Y(i\omega)$ or $Z(i\omega)$. These functions may admit a series expansion in the neighbourhood of the origin. Suppose one can select a certain neighbourhood where the only relevant terms of the expansion are the -1 , 0 and $+1$ powers of $i\omega$. One can then speak of either a parallel or a series equivalent circuit, in that particular neighbourhood and to a specified degree of accuracy, comprising a capacitive, a resistive and an inductive term. Of course, this argument can be extended to the study of the asymptotic behaviour of those same functions.

We applied this kind of analysis to the second parallel component of the sheath and arrived at the conclusion that this can indeed be given an equivalent circuit interpretation but under certain restrictive conditions only. At high frequency, the second component approaches a simple capacitance that is given by

$$C(\infty) = \frac{\epsilon_0}{X_0} \quad (16)$$

per unit area. This approach is affected by an error smaller than 10% for $\theta > 11$. The sheath behaves as though it were a capacitor with no dielectric. At low frequency, the second component approaches a series association of a capacitance, an inductance and a resistance that are given by

$$\begin{aligned} C(0) &= \frac{\epsilon_0(1 + \lambda^2/6)}{X_0} \\ L(0) &= -\frac{c\lambda^2\tau_{10}^3}{40\epsilon_0} \\ R_i(0) &= \frac{c\lambda^2\tau_{10}^2}{12\epsilon_0} \end{aligned} \quad (17)$$

per unit area. This approach is affected by an error smaller than 10% for $\theta < 1.2$.

We can therefore propose for the plasma sheath two equivalent circuits, one holding in the low frequency limit and the other one in the high frequency limit. The arrangement and nature of the circuit elements are shown in the diagrams on figure 2 while their values are given by equations (15), (16) and (17).

3.2. Some numerical results

The complex function $-(\theta^2/\lambda^2)\Psi^{-1}(\lambda, \theta)$ represents in equation (14) the ion conductance plus the susceptance of the normalized sheath admittance $Y/(\epsilon_0\Pi_1^2/c)$. That function was tabulated by an automatic numerical method with the help of a

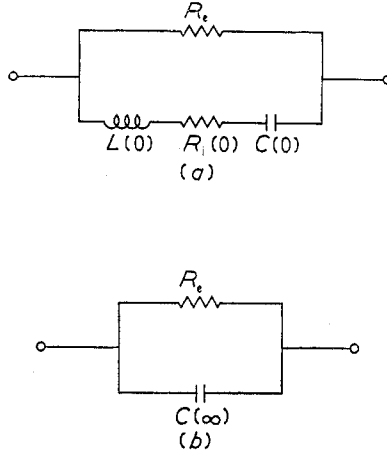

Figure 2. The equivalent circuit of the plasma sheath in (a) the low frequency and (b) the high frequency limits. The values of the circuit elements are given in equations (15), (16) and (17).

PDP-15 computer in this laboratory. On the basis of these data the normalized ion conductance $G_1/(\epsilon_0\Pi_1^2/c)$ and the normalized sheath susceptance, $B/(\epsilon_0\Pi_1^2/c)$, were plotted against θ and for different values of the parameter λ as shown in figures 3 and 4. The values given to this parameter are $\lambda = 2, 3$ and 4 which, according to equation (12), refer to the values $\eta_0 = 4, 14.6$ and 40 of the applied dc bias.

The ion conductance (see figure 3) exhibits a pronounced oscillating behaviour along the θ axis but it damps out and tends asymptotically to zero as the frequency increases.

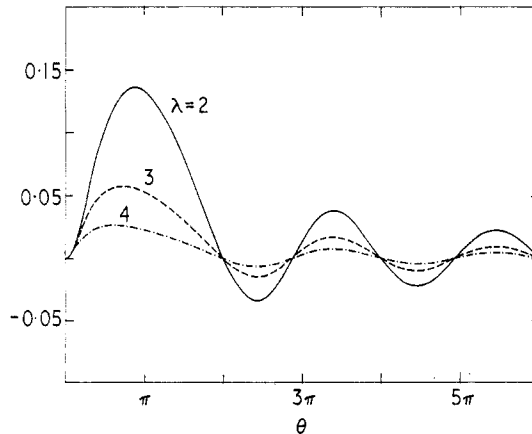

Figure 3. The ion contribution to the normalized sheath conductance $G_1/(\epsilon_0\Pi_1^2/c)$ against the transit angle θ of the ion in the sheath. The plotted curves are labelled with the value of the parameter λ .

One should notice that the zeros of the ion conductance do not depend on the particular value of λ . Notice also that whenever the transit angle equals an even multiple of π one has a zero and a sign reversal.

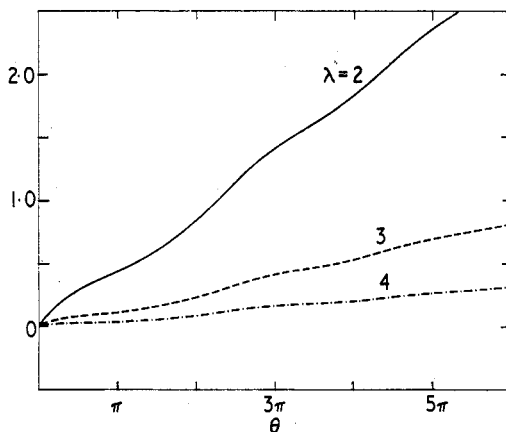

Figure 4. The normalized sheath susceptance $B/(\epsilon_0 \Pi_1^2/c)$ against the transit angle θ of the ion in the sheath. The plotted curves are labelled with the value of the parameter λ .

The susceptance (see figure 4), though oscillating, is a monotone increasing function along the θ axis. At both the low and the high frequency limits the susceptance is proportional to the frequency thereby implying a low frequency and a high frequency equivalent capacitance $C(0)$ and $C(\infty)$ respectively. The ratio $C(0)/C(\infty)$ obtained numerically is found to equal $(1 + \lambda^2/6)$ in accordance with what can be deduced from equations (16) and (17).

3.3. The rf probe method near the ion plasma frequency

We wish to emphasize the advantage in employing the rf probe technique at frequencies near the ion plasma frequency.

It has become clear by now, in the light of the foregoing theory, that the conductance and the susceptance of the sheath are two quantities of comparable magnitude at frequencies of the order of the ion plasma frequency. That is not the case at very low or at very high frequencies when either the conductive term or the capacitive term alone dominate the sheath behaviour.

One can therefore say that rf probe measurements near the ion plasma frequency yield both the conductance and the susceptance of the sheath thus offering the possibility of obtaining the simultaneous measurement of the electron temperature and the plasma density.

In order to illustrate this possibility consider a rf probe operating at floating potential $\eta_0 = \eta_0^*$ and at a fixed frequency ω . Given a singly ionized species of known ion mass m_1 there corresponds a specific floating potential η_0^* (equation (9)). It then follows that, in view of equation (12), $\lambda = \Pi_1 \tau_{10}$ will also be a constant and that $\theta = \tau_{10} \omega$ will vary as the reciprocal of Π_1 . Now, recalling equation (14) one realizes that the normalized sheath admittance $Y/(\epsilon_0 \Pi_1^2/c)$ is a function of Π_1 only, that is to say, of the ion density at the plasma edge. One draws the conclusion that,

under the stated circumstances, the phase angle of the sheath admittance is a measure of the plasma density. The electron temperature can then be obtained from the magnitude of the sheath admittance.

Acknowledgments

The author would like to thank Fernando Sequeira for his helpful comments on equivalent circuits and J. Pinto Chagas for his assistance with the computing program. The author is also grateful to J. Sousa Lopes for his kind interest in the work.

References

- BIRDSALL, C. K., and BRIDGES, W. B., 1966, *Electron Dynamics of Diode Regions* (New York: Academic Press), ch. 2.
- BOHM, D., 1949, *The Characteristics of Electrical Discharges in Magnetic Fields*, eds A. Guthrie and R. K. Wakerling (New York: McGraw-Hill), ch. 3.
- BUCKLEY, R., 1966, *Proc. R. Soc. A*, **290**, 186-219.
- 1967, *J. Plasma Phys.*, **1**, 171-91.
- BUTLER, H. S., and KINO, G. S., 1963, *Phys. Fluids*, **6**, 1346-55.
- CRAWFORD, F. W., and GRARD, R., 1966, *J. appl. Phys.*, **37**, 180-3.
- LLEWELLYN, F. B., 1941, *Electron Inertia Effects* (London: Cambridge University Press), ch. 2.
- MONTGOMERY, R. M., and HOLMES, R. A., 1963, *Proc. 5th bienn. Symp. on Gas Dynamics*, eds T. P. Anderson, R. W. Springer and R. C. Warder, Jr. (Evanston, Ill.: Northwest University Press), ch. 7.
- OLIVER, B. M., CLEMENTS, R. M., and SMY, P. R., 1970, *J. appl. Phys.*, **41**, 2117-22.
- SELF, S. A., 1963, *Phys. Fluids*, **6**, 1762-8.
- 1965, *J. appl. Phys.*, **36**, 456-9.
- TOEPPER, A. J., 1967, *Phys. Fluids*, **10**, 1599-600.
- VIRMONT, J., 1969, *Proc. 9th Int. Conf. on Phenomena in Ionized Gases, Bucharest 1969* (Bucharest: Publishing House of the Academy of Sciences of Socialist Republic of Romania), p. 610.